

SPIDEX® – die elastische Kupplung

SPIDEX® – the elastic coupling



- Drehelastisch
- Schwingungsdämpfend
- Axial steckbar
- Durchschlagsicher
- Wartungsfrei
- Nabenwerkstoffe:
Aluminium (Al), Grauguss (GG/GGG),
Sinterstahl (Si), Stahl (St)

- Torsional elasticity
- Dampening
- Blind assembly
- Safe against break-down
- No maintenance
- Hub material:
Aluminium (Al), Cast Iron (GG/GGG),
Sintered Steel (Si), Steel (St)

Funktionsweise *Technical descripton*

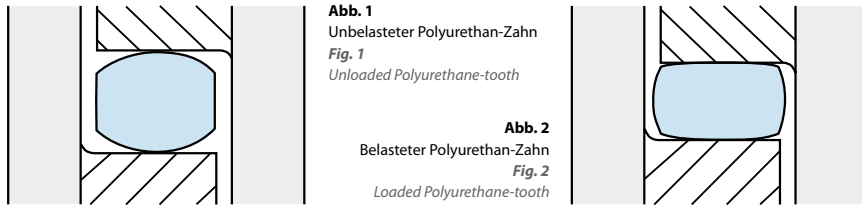

Kupplung bestehend aus:
Zwei Kupplungsstaben mit
elastischem Zahnkranz
Coupling assembled:
Two hubs with elastic spider



Elastische Kupplungen sind in der Lage, kurzzeitige Drehmomentstöße durch zeitweilige elastische Speicherung eines Teiles der Stoßenergie zu mildern. Der Ungleichförmigkeitsgrad der Bewegungs- und Kraftübertragung wird somit kleiner. Elastische Kupplungen dämpfen den Körperschall und tragen somit zur Geräuschminderung bei. Die elastische SPIDEX®-Kupplung überträgt das Drehmoment formschlüssig und durchschlagsicher. Der ballig profilierte Evolventenzahn (Abb.1) gestattet den Ausgleich von Radial- und Winkelverlagerungen der zu verbindenden Wellen. Er besteht aus einem thermoplastischen Polyurethan-Elastomer, ist ausschließlich auf Druck belastbar und zeichnet sich darüber hinaus durch hohe Verschleißfestigkeit und Elastizität, gute Dämpfungseigenschaften und gute Beständigkeit gegen Öle, Fette, viele Lösemittel, Witterungseinflüsse und Ozon aus. Hinzu kommt eine gute Hydrolyse- und Tropenbeständigkeit.

Die Einsatztemperaturen liegen zwischen $-40\text{ }^{\circ}\text{C}$ und $+100\text{ }^{\circ}\text{C}$. Kurzzeitige Temperaturspitzen bis $+120\text{ }^{\circ}\text{C}$ sind zulässig.

Die Standardhärte des Zahnkranzes beträgt 92° Shore A. Für niedrige Drehmomente kann auch ein Zahnkranz mit 80° Shore A und für höhere Drehmomente mit 95° bis 98° Shore A eingesetzt werden. Durch die aus Abb. 1 und Abb. 2 zu ersehende Balligkeit nehmen die Zähne des Zahnkranzes mit zunehmender Verformung eine überproportional wachsende Verformungsenergie auf.

Der Wert der Federsteife CT des Zahnkranzes nimmt mit Vergrößerung des relativen Drehwinkels f zu. Folglich arbeitet die Kupplung bei geringer Kraftübertragung relativ weich und mit zunehmendem Drehmoment immer härter. Hieraus ergibt sich eine progressive Federkennlinie gemäß Abb. 3. Die dynamische Federkennlinie hat einen geringfügig steileren Verlauf.

Die in Abb. 3 dargestellte Dämpfungsarbeit bewirkt die in Abb. 4 ersichtliche Dämpfung von Drehmomentstößen.

Ein besonderer Vorteil der progressiven Federkennlinie liegt im Resonanzverhalten der SPIDEX®-Kupplung. Da die kritische Resonanzdrehzahl abhängig von der Federsteife CT ist, letztere sich jedoch mit Verschiebung des Arbeitspunktes ändert, ergibt sich eine Verstimmung des Systems gemäß Abb. 5, welche die Gefahr des Aufschaukelns verringert.

Die progressive Kennlinie schützt somit vor allem die Kupplung gegen unzulässige Überbeanspruchung. Darüber hinaus kann die Federsteife CT durch eine entsprechende Wahl der Shorehärte beeinflusst werden. Eine größere Shorehärte verlagert die Resonanzdrehzahl in einen höheren, eine niedrigere Shorehärte in einen niedrigeren Bereich. Im Zweifelsfalle empfehlen wir eine Berechnung des Systems mittels der antriebs- und lastseitigen Massenträgheitsmomente.

Elastic couplings reduce intermittent short period torsional shocks, by briefly storing elastically part of this shock energy. Any degree of uneven movement and load transference is consequently reduced. Elastic couplings restrain body resonance, and therefore contribute to noise reduction. The elastic SPIDEX®-coupling transmits the torque safe against break-down. The convex generated profiled tooth crown, see fig. 1, allows compensation of radial and angular displacements of the two connected shafts. It consists of a thermoplastic Polyurethane elastomer, which is exclusively pressure loaded and designed for high abrasion resistance and elasticity, and to have good damping characteristics, and to be resistant to oils, greases, many solvents, atmospheric effects and ozone, as well as good resistance to hydrolysis in tropical conditions.

The operating temperatures are between $-40\text{ }^{\circ}\text{C}$ and $+100\text{ }^{\circ}\text{C}$. Short temperature peaks up to $+120\text{ }^{\circ}\text{C}$ are admissible.

The standard hardness of the spider is 92° Shore A. For low torques a spider of 80° Shore A, can be used and for higher torques a spider of 95° to 98° Shore A, can be used. From figures 1 and 2, it can be seen that the convex rim of the tooth takes higher proportion of deformation-energy, the more deformation increases. The value of the torsional stiffness CT of the tooth crown increases with the torsional angle f . Consequently, the coupling is relatively soft under small load conditions and becomes harder and harder as the torque increases. This causes a progressive torsion curve, as shown in fig. 3. The dynamic torsion curve has an insignificantly steeper course.

The damping energy shown in fig. 3 results in the damping of torque shocks as shown in fig. 4.

Special advantage of the progressive torsion characteristic is in the resonance suppression achieved by the SPIDEX®-coupling, as the critical resonance speed depends on the torsional stiffness CT (see fig. 5).

The progressive curve therefore mainly protects the coupling against inadmissible overstressing. Furthermore, the torsional stiffness CT of the spider can be influenced by the choice of an appropriate Shore hardness material. A larger Shore hardness moves the resonance speed higher, and a lower Shore hardness moves resonance speed into a lower range. If in doubt, we recommend a calculation of the system parameters by using the moments of inertia of the driving and driven sides.



Abb. 3
Progressive Drehfederkennlinie mit Dämpfung erzeugender Hysterese
Fig. 3

Progressive torsional characteristic with damping, effected by hysteresis

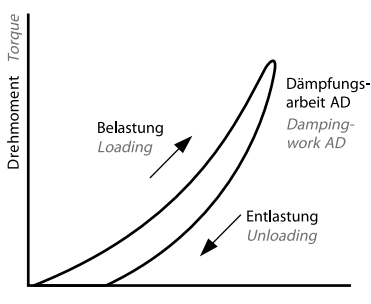

Abb. 4
Drehmomentstoß mit und ohne Dämpfung
Fig. 4

Torque shock with and without damping

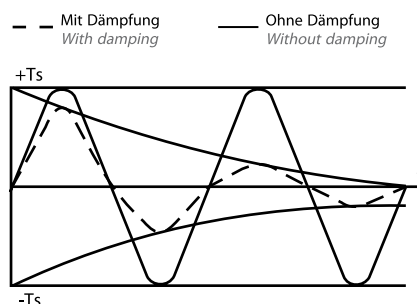

Abb. 5
Resonanzverhalten elastischer Kupplungen mit linear und progressiv ansteigender Drehfederkennlinie
Fig. 5

Resonance suppression of elastic couplings with linear and progressively increasing torsional characteristic

Typenbezeichnung Kupplungsnahe *Model type of hub*

KL		ST	A 38/45 .		A 35 x 31	L = 70	SO						
Standard <i>Standard</i>	-												
Klemmnahe <i>Clamping hub</i>	KL												
Nabenwerkstoff <i>Material of hub</i>			Nabengröße/Nabenausführung <i>Size/Design of hub</i>		Beispiel Wellenbohrung <i>Example finish bores</i>		Sonderbearbeitung <i>Special machining</i>						
Aluminium / <i>Aluminium</i>	ALU		Nabenausführung A / <i>Hub A</i>	A15	Nabenausführung B / <i>Hub B</i>	A14/16	Ung.	Ungebohrt / <i>Unbored</i>	-	Standard <i>Standard</i>			
Sinterstahl / <i>Sintered steel</i>	SI			A19		A19/24	Vorg.	Vorgebohrt / <i>Prebored</i>	38H7	ISO-Standard H7 **	SO	Sonderzeichnung <i>Special drawing</i>	
Grauguss / <i>Cast iron</i>	GG			A24		CJ24/32	B17	Konisch / <i>Tapered</i> *	F	Zöllig / <i>Inch bored</i> ***			
Sphäroguss / <i>SG</i>	GGG			A28		A28/38	*** SAE 16/32Z13	SAE	Profile <i>Splines</i>				
Stahl / <i>Steel</i>	ST			A38		A38/45	*** A35x31	DIN 5482					
				A42		A42/55	*** N30x2x14x9G	DIN 5480					
				A48		A48/60							
				A55		A55/70							
				A65		A65/75							
				A75		A75/90							
				A90		A90/100							
				A100		A100/110							
			A110	A110/125									
			A125	A125/145									

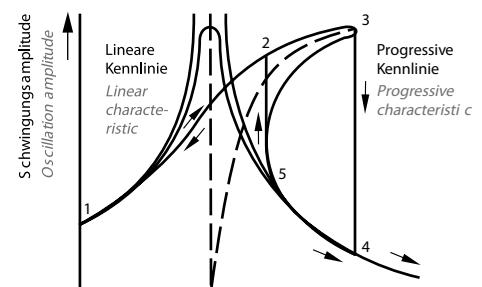
* Siehe Seite 10 / *See page 10*

** Siehe Seite 11 / *See page 11*

*** Siehe Seite 12 / *See page 12*

Typenbezeichnung Kupplungsflansch *Model type of flange*

GGG		A 38 . FLANSCH	F		
Flanschwerkstoff <i>Material of flange</i>		Flanschtyp <i>Type of flange</i>	Flanschausführung <i>Design of flange</i>		
Sphäroguss SG GGG40	GGG		A28	-	Ungebohrt <i>Unbored</i>
			A38	F	Durchgangslöcher <i>Through holes</i>
			A42	BF	Gewindebohrungen <i>Threaded holes</i>
			A48	CFA	Ausführung für Hydraulikpumpen Fabrikat LINDE
			A55	CFB	Designed for hydraulic pumps manufacturer LINDE
			A65	CFD	
			A75		
		A90			
		A100			

Der Auswahlprozess zur Größenbestimmung

Schritt 1: Bestimmung des Nenndrehmoments Ihrer Anwendung:

$$T_{KN} [\text{Nm}] = \frac{P[\text{kW}] \times 9550}{U/\text{min} [1/\text{min}]}$$

Schritt 2: Berechnung des Betriebsfaktors Ihrer Anwendung mit der Tabelle auf Seite 5. Der Gesamtbetriebsfaktor (K) ergibt sich aus:

$$K = K1 * x K2 * x K3 *$$

Schritt 3: Berechnung des konstruktiven Drehmoments (ΔT_{Kmax}) Ihrer Anwendung.

$$\text{Konstruktives Drehmoment } (\Delta T_{Kmax}) = \text{Nenndrehmoment } (T_{KN}) \times \text{Betriebsfaktor } (K).$$

Schritt 4: Unter Verwendung der Elastomer- Leistungsdatentabellen auf der Seite 7 den Urethan-Shore-Härtegrad auswählen, der am Besten den relativen Dämpfungsanforderungen Ihrer Anwendung entspricht.

Schritt 5: Finden Sie als nächstes die Spalten, in denen die Werte T_{KN} und T_{Kmax} in Nm gelistet sind und vergleichen Sie diese mit dem Wert ΔT_{Kmax} für Ihre Anwendung. Stellen Sie sicher, dass die Werte des Mitnehmers (Sterns) größer als die Anwendungswerte sind.

Schritt 6: Nachdem die Größe unter Verwendung der Drehmomentwerte ausgewählt ist, stellen Sie mit Hilfe der Tabelle auf Seite 8 sicher, dass der erforderliche Bohrungsdurchmesser in die Kupplung passt.

Schritt 7: Überprüfen Sie sorgfältig das Gesamtmaß der Kupplung, um zu gewährleisten, dass die Kupplung in den Einbauraum passt.

Definition der Begriffe

T_{KN}	Nenndrehmoment der Kupplung
T_{Kmax}	Maximales Drehmoment der Kupplung
$P [\text{kW}]$	Leistung in Kilowatt
$U/\text{min} [1/\text{min}]$	Umdrehungen pro Minute
Nm	Newtonmeter
ΔT_{Kmax}	Maximales Drehmoment der Anwendung
T_{KW}	Variierende Belastung einer Anwendung in Kilowatt (DIN 740 Teil 2)
K	Betriebsfaktor

Selection process for sizing determination

Step 1: Determine the nominal torque of your application:

$$T_{KN} [\text{Nm}] = \frac{P[\text{kW}] \times 9550}{U/\text{min} [1/\text{min}]}$$

Step 2: Calculate your Application Service Factor using the charts on page 5. The total Service Factor (K) will be:

$$K = K1 * x K2 * x K3 *$$

Step 3: Calculate the design torque (ΔT_{Kmax}) of your application.

$$\text{Design torque } (\Delta T_{Kmax}) = \text{Nominal torque } (T_{KN}) \times \text{service factor } (K).$$

Step 4: Using the Elastomer performance data charts on page 7 select the urethane shore hardness which best corresponds to your relative damping needs in the application.

Step 5: Next find the columns listing T_{KN} and T_{Kmax} values listed in Nm and compare them against the ΔT_{Kmax} figure for your application. Make sure that the spider/coupling size values are larger than the application values.

Step 6: Once the size is selected using the torque values, check the table on page 8 to make sure the bore size needed will fit in the coupling.

Step 7: Double check the overall dimensions of the coupling to ensure that it will fit in the space allowed for the coupling in the application.

Definition of terms

T_{KN}	Rated coupling torque
T_{Kmax}	Maximum torque of the coupling
$P [\text{kW}]$	Power in kilowatts
$U/\text{min} [1/\text{min}]$	Revolutions per minute
Nm	Newton meters
ΔT_{Kmax}	Maximum torque of the application
T_{KW}	Varying load of an application in kilowatts (DIN 740 part 2)
K	Application Service Factor

Anwendungs-Betriebsfaktoren *Application service factors*

K1

	Betriebsfaktor K1
Gleichmäßiger Betrieb mit kleinen Beschleunigungsmassen. Hydraulik- und Zentrifugalpumpen, kleine Generatoren, Gebläse, Lüfter, Ventilatoren, Band/Schraubenförderer.	1.0
Gleichmäßiger Betrieb mit mittleren Beschleunigungsmassen. Blechbiegemaschinen, Holzbearbeitungsmaschinen, Walzwerke, Textilmaschinen, Mischer.	1.2
Ungleichmäßiger Betrieb mit mittleren Beschleunigungsmassen. Rotierende Öfen, Druckpressen, Generatoren, Schredder, Wickelmaschinen, Soeinmaschinen, Pumpen für dickflüssige Fluide.	1.3
Ungleichmäßiger Betrieb und Stoßbelastungen mit mittleren Beschleunigungsmassen. Betonmischer, Fallhämmer, Seilbahnen, Papiermühlen, Kompressionspumpen, Propellerpumpen, Seilwinden, Zentrifugen.	1.4
Ungleichmäßiger Betrieb und starke Stoßbelastungen mit großen Beschleunigungsmassen. Bagger, Hammermühlen, Kolbenpumpen, Pressen, Erdbohrmaschinen, Scheren, Schmiedepressen, Steinbrecher.	1.6
Ungleichmäßiger Betrieb und sehr starke Stoßbelastungen mit sehr großen Beschleunigungsmassen. Kolbenkompressoren und Pumpen ohne Drehzahlregelung, schwere Walzensätze, Schweißmaschinen, Ziegelpressen, Steinbrecher.	1.8

K1

	Application service factor K1
Uniform operation with small masses to be accelerated. Hydraulic and centrifugal pumps, light generators, blowers, fans, ventilators, belt/screw conveyors.	1.0
Uniform operation with medium masses to be accelerated. Sheet metal bending machines, wood working machines, mills, textile machines, mixersg	1.2
Irregular operation with medium masses to be accelerated. Rotating ovens, printing presses, generators, shredders, winders, spinning machines, pumps for viscous fluids	1.3
Irregular operation and shocks, with medium masses to be accelerated. Concrete mixers, drop hammers, cable cars, paper mills, compression pumps, propeller pumps, rope winders, centrifuges	1.4
Irregular operation and heavy shocks, with large masses to be accelerated. Excavators, hammer mills, piston pumps, presses, rotary boring machines, shears, forge presses, stone crushers	1.6
Irregular operation and very heavy shocks, with very large masses to be accelerated. Piston type compressors and pumps without speed variations, heavy roll sets, welding machines, brick presses, stone crushers.	1.8

K2 – für Anläufe pro Stunde

Anläufe pro Stunde	100	200	400	800
Betriebsfaktor K2	1.0	1.2	1.4	1.6

K2 – for starts per hour

Starts per hour	100	200	400	800
Service factor K2	1.0	1.2	1.4	1.6

K3 – für Umgebungstemperaturen

Umgebungstemperatur	-30 bis +30 °C	+40 °C	+60 °C	+80 °C
Betriebsfaktor K3	1.0	1.2	1.4	1.8

K3 – for ambient temperature

Ambient temperature	-30 to +30 °C	+40 °C	+60 °C	+80 °C
Service factor K3	1.0	1.2	1.4	1.8

SPIDEX[®]-Kupplungen für IEC-Normmotoren, Zahnkranz 92° Shore A

SPIDEX[®]-Couplings for IEC-standard motors, spider 92° Shore A

Motor- bau- größe Motor size	Welle Shaft D x l [mm]		n = 750 [1/min] Leistung P Power P		Größe Size	T _k max [Nm]	n = 1000 [1/min] Leistung P Power P		Größe Size	T _k max [Nm]	n = 1500 [1/min] Leistung P Power P		Größe Size	T _k max [Nm]	n = 3000 [1/min] Leistung P Power P		Größe Size	T _k max [Nm]			
	= 1500 [1/min]	= 3000 [1/min]	kW	T _{AN} [Nm]			kW	T _{AN} [Nm]			kW	T _{AN} [Nm]			kW	T _{AN} [Nm]					
56	9 x 20		-	-	14/16	15	-	-	14/16	15	0.06	0.4	14/16	15	0.09	0.3	14/16	15			
					15				15		0.09	0.6	15		0.12	0.4	15				
63	11 x 23		-	-			-	-			0.12	0.9			0.18	0.6					
											0.18	1.2			0.25	0.9					
71	14 x 30		-	-			-	-			0.25	1.8			0.37	1.3					
											0.37	2.5			0.55	1.9					
80	19 x 40		-	-	19/24	20	0.37	3.7	19/24	20	0.55	3.7	19/24	20	0.75	2.5	19/24	20			
							0.55	5.5			0.75	5.0			1.1	3.7					
90 S	24 x 50		-	-			0.75	7.9			1.1	7.5			1.5	4.9					
90 L			-	-			1.1	11			1.5	10			2.2	7.4					
100 L	28 x 60		0.75	11	24/32	70	1.5	15	24/32	70	2.2	15	24/32	70	3	9.8	24/32	70			
			1.1	16							3	20			3	9.8					
112 M			1.5	21			2.2	22			4	27			4	13					
132 S	38 x 80		2.2	29	28/38	190	3	30	28/38	190	5.5	36	28/38	190	5.5	18	28/38	190			
															7.5	25					
132 M			3	40			4	39			7.5	49									
							5.5	55													
160 M	42 x 110		4	54	38/45	380	7.5	74	38/45	380	11	72	38/45	380	11	35	38/45	380			
			5.5	74											15	49					
160 L			7.5	100			11	108			15	98			18.5	60					
180 M	48 x 110				42/55	530			42/55	530	18.5	121	42/55	530	22	72	42/55	530			
180 L			11	147			15	147			22	144									
200 L	55 x 110		15	196			18.5	185			30	195			30	97					
							22	215			37	117									
225 S	60 x 140	55 x 110	18.5	245	48/60	620			48/60	620	37	245	48/60	620							
225 M			22	294			30	292			45	294			45	146					
250 M	65 x 140	60 x 140	30	390	65/75	1250	37	361	55/70	820	55	357	55/70	820	55	176	48/60	620			
280 S	75 x 140	65 x 140	37	490			45	440	65/75	1250	75	487	65/75	1250	75	245	55/70	820			
280 M			45	585			55	536			90	584			90	294					
315 S	80 x 170		55	715	75/90	2560	75	730	75/90	2560	110	714	75/90	2560	110	350					
315 M			75	970	90/100	4800	90	876			132	857			132	420	65/75	1250			
315 L			90	1170			110	1070	90/100	4800	160	1030	90/100	4800	160	513					
																			110	1420	132
355 L	95 x 170		75 x 140	132	1710			160	1550			250	1610			250	801	75/90	2560		
				160	2070			100/110	6600			200	1930			315	2020			315	1010
				200	2580							250	2420								
400 L	100 x 210	80 x 170	250	3230	110/125	9600	315	3040	100/110	6600			100/110	6600	355	1140					
											2280				400	1280					
											2560										

Die Kupplungsvorauswahl erfolgte für den Normalbetrieb ohne Berücksichtigung von Betriebsfaktoren.
Coupling selection made for normal operation. For other conditions please notify the safety factors.

Technische Daten *Technical data*

Zahnkranz <i>Spider</i>	Größe <i>Size</i>	Drehmoment <i>Torque</i> [Nm]			Max. Drehzahl <i>Max. rotation</i> <i>n</i> [1/min]		Verdrehwinkel <i>Torsional angle</i>		Drehfedersteife <i>Torsional stiffness</i> <i>C_{dyn}</i> [Nm/rad]				Verhältnis- mäßige Dämpfung <i>Relatively</i> <i>damping</i>
		Nenn <i>Contin.</i> <i>T_{KN}</i>	Maximal <i>Maximum</i> <i>T_{Kmax}</i>	Wechsel <i>Alternat.</i> <i>T_{KW}</i>	V= 30 m/s	40 m/s	<i>T_{KN}</i> <i>Φ_{KN}</i>	<i>T_{Kmax}</i> <i>Φ_{Kmax}</i>	1.00 <i>T_{KN}</i>	0.75 <i>T_{KN}</i>	0.5 <i>T_{KN}</i>	0.25 <i>T_{KN}</i>	
80° Shore Skala A Farbe: Blau <i>Scale A</i> <i>Color:</i> <i>Blue</i>	14/16, 15	4	8	1	19000	–	6.4°	10°	–	–	–	–	0.85
	19/24	4.9	9.7	1.3	14000	19000	3.2°	5°	0.25 x 10 ³	0.21 x 10 ³	0.17 x 10 ³	0.11 x 10 ³	
	24/32	17	34	4.4	10600	14000			0.90 x 10 ³	0.75 x 10 ³	0.60 x 10 ³	0.40 x 10 ³	
	28/38	46	92	12	8500	11800			2.30 x 10 ³	1.93 x 10 ³	1.52 x 10 ³	1.03 x 10 ³	
	38/45	93	185	24	7100	9500			4.10 x 10 ³	3.45 x 10 ³	2.75 x 10 ³	1.85 x 10 ³	
	42/55	130	260	34	6000	8000			5.90 x 10 ³	5.05 x 10 ³	4.00 x 10 ³	2.70 x 10 ³	
	48/60	150	300	39	5600	7100			8.00 x 10 ³	6.81 x 10 ³	5.30 x 10 ³	3.60 x 10 ³	
	55/70	180	360	47	4750	6300			9.95 x 10 ³	8.45 x 10 ³	6.71 x 10 ³	4.50 x 10 ³	
	65/75	205	410	53	4250	5600			13.05 x 10 ³	11.08 x 10 ³	8.79 x 10 ³	5.89 x 10 ³	
	75/90	475	950	124	3550	4750			22.00 x 10 ³	18.44 x 10 ³	14.65 x 10 ³	9.85 x 10 ³	
	90/100	1175	2350	306	2800	3750			45.00 x 10 ³	38.20 x 10 ³	30.05 x 10 ³	20.00 x 10 ³	
	100/110	1610	3220	419	2500	3350			75.69 x 10 ³	64.00 x 10 ³	50.20 x 10 ³	34.00 x 10 ³	
	110/125	1950	3900	507	2240	3000			100.00 x 10 ³	84.00 x 10 ³	67.00 x 10 ³	45.00 x 10 ³	
	125/145	2440	4880	634	2000	2650			140.00 x 10 ³	118.00 x 10 ³	94.00 x 10 ³	63.06 x 10 ³	
92° Shore Skala A Farbe: Weiß <i>Scale A</i> <i>Color:</i> <i>White</i>	14/16, 15	7.5	15	2.0	19000	–	6.4°	10°	0.38 x 10 ³	0.31 x 10 ³	0.24 x 10 ³	0.14 x 10 ³	0.75
	19/24	10	20	2.6	14000	19000	3.2°	5°	1.28 x 10 ³	1.05 x 10 ³	0.80 x 10 ³	0.47 x 10 ³	
	24/32	35	70	9.1	10600	14000			4.86 x 10 ³	3.98 x 10 ³	3.01 x 10 ³	1.79 x 10 ³	
	28/38	95	190	25	8500	11800			10.90 x 10 ³	8.94 x 10 ³	6.76 x 10 ³	4.01 x 10 ³	
	38/45	190	380	49	7100	9500			21.05 x 10 ³	17.26 x 10 ³	13.05 x 10 ³	7.74 x 10 ³	
	42/55	265	530	69	6000	8000			23.74 x 10 ³	19.47 x 10 ³	14.72 x 10 ³	8.73 x 10 ³	
	48/60	310	620	81	5600	7100			36.70 x 10 ³	30.09 x 10 ³	22.75 x 10 ³	13.49 x 10 ³	
	55/70	410	820	107	4750	6300			50.72 x 10 ³	41.59 x 10 ³	31.45 x 10 ³	18.64 x 10 ³	
	65/75	625	1250	163	4250	5600			97.13 x 10 ³	79.65 x 10 ³	60.22 x 10 ³	35.70 x 10 ³	
	75/90	1280	2560	333	3550	4750			113.32 x 10 ³	92.92 x 10 ³	70.26 x 10 ³	41.65 x 10 ³	
	90/100	2400	4800	624	2800	3750			190.09 x 10 ³	155.87 x 10 ³	117.86 x 10 ³	69.86 x 10 ³	
	100/110	3300	6600	858	2500	3350			253.08 x 10 ³	207.53 x 10 ³	156.91 x 10 ³	93.01 x 10 ³	
	110/125	4800	9600	1248	2240	3000			311.61 x 10 ³	255.52 x 10 ³	193.20 x 10 ³	114.52 x 10 ³	
	125/145	6650	13300	1729	2000	2650			474.86 x 10 ³	389.39 x 10 ³	294.41 x 10 ³	174.51 x 10 ³	
98° Shore Skala A Farbe: Rot <i>Scale A</i> <i>Color: Red</i>	14/16, 15	12.5	25	3.3	19000	–			0.56 x 10 ³	0.46 x 10 ³	0.35 x 10 ³	0.21 x 10 ³	0.7
	19/24	17	34	4.4	14000	19000	6.4°	10°	2.92 x 10 ³	2.39 x 10 ³	1.81 x 10 ³	1.07 x 10 ³	
	24/32	60	120	16	10600	14000	3.2°	5°	9.93 x 10 ³	8.14 x 10 ³	6.16 x 10 ³	3.65 x 10 ³	
	28/38	160	320	42	8500	11800			26.77 x 10 ³	21.95 x 10 ³	16.60 x 10 ³	9.84 x 10 ³	
	38/45	325	650	85	7100	9500			48.57 x 10 ³	39.83 x 10 ³	30.11 x 10 ³	17.85 x 10 ³	
	42/55	450	900	117	6000	8000			54.50 x 10 ³	44.69 x 10 ³	33.79 x 10 ³	20.03 x 10 ³	
	48/60	525	1050	137	5600	7100			65.29 x 10 ³	53.54 x 10 ³	40.48 x 10 ³	24.00 x 10 ³	
	55/70	685	1370	178	4750	6300			94.97 x 10 ³	77.88 x 10 ³	58.88 x 10 ³	34.90 x 10 ³	
95° Shore Skala A Farbe: Rot <i>Scale A</i> <i>Color: Red</i>	65/75	940	1880	244	4250	5600	3.2°	5°	129.51 x 10 ³	106.20 x 10 ³	80.30 x 10 ³	47.60 x 10 ³	
	75/90	1920	3840	499	3550	4750			197.50 x 10 ³	161.95 x 10 ³	122.45 x 10 ³	72.58 x 10 ³	
	90/100	3600	7200	936	2800	3750			312.20 x 10 ³	256.00 x 10 ³	193.56 x 10 ³	114.73 x 10 ³	
	100/110	4950	9900	1287	2500	3350			383.26 x 10 ³	314.27 x 10 ³	237.62 x 10 ³	140.85 x 10 ³	
	100/125	7200	14400	1872	2240	3000			690.06 x 10 ³	565.85 x 10 ³	427.84 x 10 ³	253.60 x 10 ³	
	125/145	10000	20000	2600	2000	2650			1343.64 x 10 ³	1101.79 x 10 ³	833.06	493.79 x 10 ³	
64° Shore Skala D Farbe: Grün <i>Scale D</i> <i>Color:</i> <i>Green</i>	24/32	75	150	19.5	10600	14000	2.5°	3.6°	15.11 x 10 ³	12.39 x 10 ³	9.37 x 10 ³	5.55 x 10 ³	0.6
	28/38	200	400	52	8500	11800			27.52 x 10 ³	22.57 x 10 ³	17.06 x 10 ³	10.12 x 10 ³	
	38/45	405	810	105	7100	9500			70.15 x 10 ³	57.52 x 10 ³	43.49 x 10 ³	25.78 x 10 ³	
	42/55	560	1120	146	6000	8000			79.86 x 10 ³	65.49 x 10 ³	49.52 x 10 ³	29.35 x 10 ³	
	48/60	655	1310	170	5600	7100			95.51 x 10 ³	78.32 x 10 ³	59.22 x 10 ³	35.10 x 10 ³	
	55/70	825	1650	215	4750	6300			107.52 x 10 ³	88.50 x 10 ³	66.91 x 10 ³	39.66 x 10 ³	
	65/75	1175	2350	306	4250	5600			151.09 x 10 ³	123.90 x 10 ³	93.68 x 10 ³	55.53 x 10 ³	
	75/90	2400	4800	624	3550	4750			248.22 x 10 ³	203.54 x 10 ³	153.90 x 10 ³	91.22 x 10 ³	
	90/100	4500	9000	1170	2800	3750			674.52 x 10 ³	553.11 x 10 ³	418.20 x 10 ³	247.89 x 10 ³	

Bei Umfangsgeschwindigkeit über V=30 m/s ist dynamisches Wuchten erforderlich. *For speeds of over V=30 m/s dynamic balancing is necessary.*

Einsatzbedingungen für SPIDEX®-Zahnkränze *Operating conditions for SPIDEX®-spiders*

	Standardausführung <i>Basic version</i>	Sonder-Zahnkranz <i>Special Spider</i>	
Werkstoff <i>Material</i>	Polyurethane		
Zahnkranzhärte <i>Hardness of spider</i>	80 °C Shore A	92 °C Shore A	95°/98° Shore A
Zahnkranzfarbe <i>Color of spider</i>	Blau <i>Blue</i>	Weiß <i>White</i>	Rot <i>Red</i>
Zul. Temperaturbereich Dauereinsatz <i>Permissible durable temperature range</i>	-40 °C bis +80 °C -40 °C up to +80 °C	-40 °C bis +90 °C -40 °C up to +90 °C	-30 °C bis +100 °C -30 °C up to +100 °C
Zul. kurzfristige Temperaturspitzen <i>Permissible short term temperature peaks</i>	-60 °C bis +80 °C -60 °C up to +80 °C	-50 °C bis +120 °C -50 °C up to +120 °C	-40 °C bis +120 °C -40 °C up to +120 °C
Dämpfung <i>Damping</i>	Sehr gut <i>Very Good</i>	Gut <i>Good</i>	Mittel <i>Medium</i>
Elastizität <i>Elasticity</i>	Weich <i>Soft</i>	Mittel <i>Medium</i>	Hart <i>Hard</i>
Abriebfestigkeit <i>Abrasion resistance</i>	Sehr gut <i>Very good</i>	Sehr gut <i>Very good</i>	Gut <i>Good</i>
Dauerfestigkeit <i>Durability</i>	Ausgezeichnet <i>Excellent</i>	Sehr gut <i>Very good</i>	Sehr gut <i>Very good</i>
Einsatzbereiche <i>Typical applications</i>	Allgemeine Antriebe, auch mit Dreh- schwingungsgefährdung <i>Normal drives also resonance speed</i> <i>possibility</i>	Allgemeine Antriebe <i>Normal drives</i>	Allgemeine Antriebe mit erhöhten Belastungen <i>Normal drives with high</i> <i>performance</i>
			Hohe Belastbarkeit mit geringem Verdrehwinkel <i>High performance with small</i> <i>torsional angle</i>

Abmessungen SPIDEX®-Kupplungen *Dimensions SPIDEX®-Couplings*

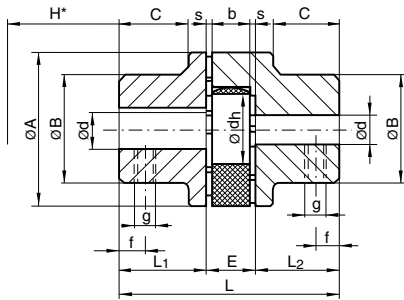

Nabenkombination A/A *Hub combination A/A*

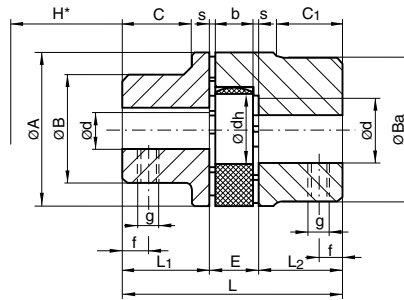

Nabenkombination A/B *Hub combination A/B*

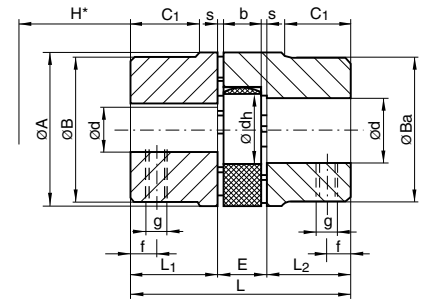

Nabenkombination B/B *Hub combination B/B*

Spidex® Type	Bohrungen Bores				Abmessungen [mm] Dimensions [mm]													Gewicht Weight [kg]	Naben Sonder- länge Special hub length [mm]	
	Fertigbohrung Finish bores				L1 +															
	Nabe A Hub A		Nabe B Hub B		A	B	Ba	L	L2	E	s	b	C	C1	dh	g	f			H*
Werkstoff: Aluminium-Druckguss <i>Material: Die cast aluminium</i>																				
A15	-	-	4	15	26	-	26	28	10	8	1	6	-	-	12	M5	5	8	0.025	-
A19/24	6	19	19	24	40	32	39	66	25	16	2	12	20	21	18	M5	10	14	0.13	55
A24/32	8	24	16	32	55	40	53	78	30	18	2	14	24	26	27	M5	10	16	0.26	60
A28/38	10	28	28	38	65	48	63	90	35	20	2.5	15	28	29	30	M6	15	18	0.46	60
A38/45	14	38	38	45	80	66	79	114	45	24	3	18	37	39	38	M8	15	19	0.90	70
Werkstoff: Grauguss (GG), Sphäroguss (GGG), Stahl (St), Sinterstahl (Si) <i>Material: Cast iron (GG), SG iron (GGG), Steel (St), Sintered steel (Si)</i>																				
A14/16 Sint	-	-	4	16	30	-	30	35	11	13	1.5	10	-	-	10	M4	5	12	0.14	18.5
A19/24 GG/St/Si	6	19	12	24	40	32	39	66	25	16	2	12	20	21	18	M5	10	14	0.35	55
A24/32 GG/St/Si	10	24	14	32	55	40	52	78	30	18	2	14	24	26	27	M5	10	16	1.0	60
A28/38 GG/St/Si	12	28	28	38	65	45	62	90	35	20	2.5	15	28	29	30	M6	15	18	1.6	80
A38/45 GG/GGG/St/Si	14	38	38	45	80	66	77	114	45	24	3	18	37	37	38	M8	15	19	2.3	110
A42/55 GG/GGG/St	19	42	42	55	95	75	94	126	50	26	3	20	40	40	46	M8	20	21	3.6	110
A48/60 GG/GGG/St	19	48	48	60	105	85	102	140	56	28	3.5	21	45	45	51	M8	20	22	4.8	110
A55/70 GG/GGG/St	19	55	55	70	120	98	118	160	65	30	4	22	52	52	60	M10	20	23	7.4	140
A65/75 GG/GGG/St	22	65	65	75	135	115	132	185	75	35	4.5	26	61	59	68	M10	20	27	10.9	140
A75/90 GG/GGG/St	30	75	75	90	160	135	158	210	85	40	5	30	69	65	80	M10	25	31	17.7	195
A90/100 GG/GGG/St	40	90	90	100	200	160	180	245	100	45	5.5	34	81	81	100	M10	25	35	29.5	140/210
A100/110 GG/GGG/St	-	-	55	110	225	-	200	270	110	50	6	38	-	89	113	M12	30	39	43.5	-
A110/125 GG/GGG/St	-	-	65	125	255	-	230	295	120	55	6.5	42	-	96	127	M16	35	43	63	-
A125/145 GG/GGG/St	-	-	65	145	290	-	265	340	140	60	7	46	-	112	147	M16	40	47	95	-

H* ist das Mindestmaß, um welches die Aggregate auseinander geschoben werden müssen, um einen radialen Ausbau zu ermöglichen.

Fertigbohrungen nach ISO-Passung H7, Passfedernut nach DIN 6885, Blatt 1 (JS9). Das Gewicht und Massenträgheitsmoment bezieht sich auf die Werkstoffe Al/GG/GGG bei max. möglichem Durchmesser d ohne Nut.

**Standardprogramm: A Nabe und B Nabe in Grauguss „GG“
B Nabe in Sphäroguss „GGG“, Stahl „St“,
Sinterstahl „Si“
A Nabe als Sonderanfertigung lieferbar
Baureihen 140/160/180 auf Anfrage**

H* is the minimum dimension required for the disassembly of the aggregates in the radial direction. Finish bores acc. to ISO standard H7, keyway acc. to DIN 6885, sheet 1 (JS9). Weight and moment of inertia in relation to the materials Al/GG/GGG with max. diameter without keyway.

**Standard program: A-hub and B-hub in cast iron „GG“
B-hub in spheroidal iron „GGG“, steel „St“,
sintered steel „Si“
A-hub available as special design
Series 140/160/180 on request**

Massenträgheitsmomente J [kgm²] (Standardnabe mit maximalem Bohrungsdurchmesser ohne Nut) Moment of inertia J [kgm²] (Standard hub with max. diameter of boring without keyway)

Nabenteil Part of coupling	Material Material	Kupplungsgröße Coupling size														
		14/16	15	19/24	24/32	28/38	38/45	42/55	48/60	55/70	65/75	75/90	90/100	100/110	110/125	125/145
Nabe A Hub A	Al	-	-	0.000010	0.00004	0.00010	0.00035	-	-	-	-	-	-	-	-	
	GG/GGG/St	-	-	0.000050	0.00025	0.00040	0.0010	0.0020	0.0030	0.0060	0.0125	0.025	0.069	-	-	
Nabe B Hub B	Al	-	0.000004	0.000020	0.00009	0.00020	0.00045	-	-	-	-	-	-	-		
	GG/GGG/St	0.00002	-	0.000050	0.00020	0.00070	0.00100	0.0030	0.0050	0.0100	0.0183	0.041	0.09	0.154	0.091	0.575
Zahnkranz Spider	Pu	-	-	0.000003	0.00001	0.00002	0.00005	0.0001	0.0002	0.0003	0.0005	0.002	0.004	0.007	0.015	0.025

Abmessungen SPIDEX®-Flanschkupplungen *Dimensions SPIDEX®-Flange Couplings*

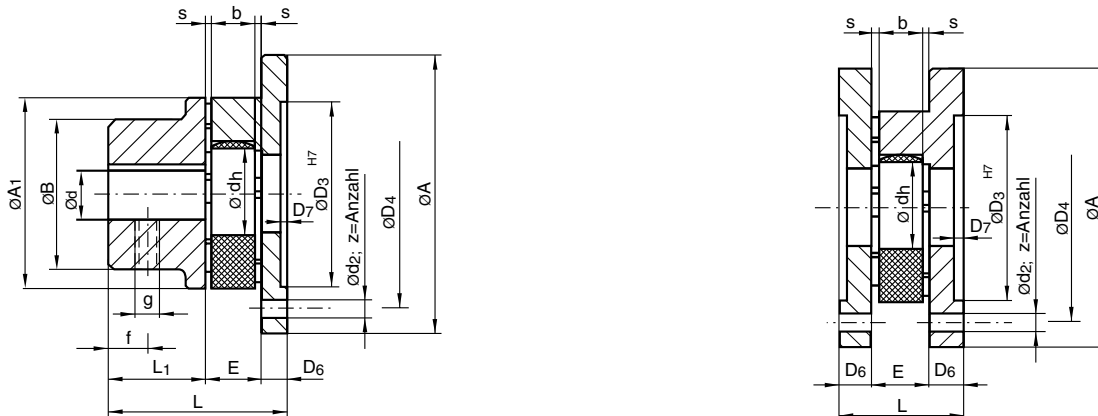

Baureihe F *Series F*

Spidex® Type	Fertigbohrung ¹⁾ Finishbores ¹⁾		Abmessungen Dimensions [mm]																Gewicht Weight [kg]	Massenträgheits- moment ²⁾ Moment of inertia ²⁾ J [kgm ²]	
	min	max ⁴⁾	A	A1	B	L1	L	E	s	b	dh	g	f	D6	D7	d2 DIN 69	z Anzahl Number	D3			D4
F 28	10	28	100	65	65	35	65	20	2.5	15	30	M8	15	10	1.5	7	6	65	80	1.18	0.0012
F 38	14	38	115	80	66	45	79	24	3	18	38	M8	15	10	1.5	7	6	80	95	1.87	0.0023
F 42	19	42	140	95	75	50	88	26	3	20	46	M8	20	12	2	9	6	95	115	3.06	0.0054
F 48	19	48	150	105	85	56	96	28	3.5	21	51	M8	20	12	2	9	8	105	125	3.88	0.0080
F 55	19	55	175	120	98	65	111	30	4	22	60	M10	20	16	2	11	8	120	145	6.21	0.0178
F 65	22	65	190	135	115	75	126	35	4.5	26	68	M10	20	16	2	11	10	135	160	8.63	0.0293
F 75	30	75	215	160	135	85	144	40	5	30	80	M10	25	19	2.5	14	10	160	185	13.2	0.0595
F 90	40	90	260	200	160	100	165	45	5.5	34	100	M12	30	20	3	14	12	200	225	22.0	0.1443

4) Wenn größere Fertigbohrungen benötigt werden, können B-Naben verwendet werden. 4) If larger bore diameters required you have to use hub type B.

Baureihe FF *Series FF*

Spidex® Type	Abmessungen Dimensions [mm]													Gewicht Weight [kg]	Massenträgheits- moment ²⁾ Moment of inertia ²⁾ J [kgm ²]
	A	L	E	s	b	dh	D6	D7	d2 DIN 69 ³⁾	z Anzahl Number	D3	D4			
FF 28	100	40	20	2.5	15	30	10	1.5	7	6	65	80	1.19	0.0015	
FF 38	115	44	24	3	18	38	10	1.5	7	6	80	95	1.66	0.0028	
FF 42	140	50	26	3	20	46	12	2	9	6	95	115	2.91	0.0072	
FF 48	150	52	28	3.5	21	51	12	2	9	8	105	125	3.35	0.0092	
FF 55	175	62	30	4	22	60	16	2	11	8	120	145	5.78	0.023	
FF 65	190	67	35	4.5	26	68	16	2	11	10	135	160	7.13	0.034	
FF 75	215	78	40	5	30	80	19	2.5	14	10	160	185	10.5	0.065	
FF 90	260	85	45	5.5	34	100	20	3	14	12	200	225	16.5	0.15	

1) Fertigbohrungen nach ISO-Passung H7, Passfedernut nach DIN 6885, Blatt 1 (JS9).

2) Gewicht und Massenträgheitsmoment für Werkstoffe GG/GGG bei maximalem Bohrungsdurchmesser ohne Nut.

3) Wenn Gewindebohrungen anstatt Durchgangsbohrungen benötigt werden, ändert sich die Flanschbezeichnung in BF bzw. BFF.

1) Finish bores acc. to ISO-standard H7, keyway acc. to DIN 6885, sheet 1 (JS9).

2) Weight and moment of inertia in relation to the materials GG/GGG with max. diameter without keyway.

3) Even threaded holes instead of through holes may be obtained, the flange sign changed into „BF“ resp. „BFF“.

Maximal zulässige Verlagerungswerte für Zahnkranzhärten 80°, 92°, 95°, 98° Shore A Max. permissible displacement values for spiders 80°, 92°, 95°, 98° Shore A

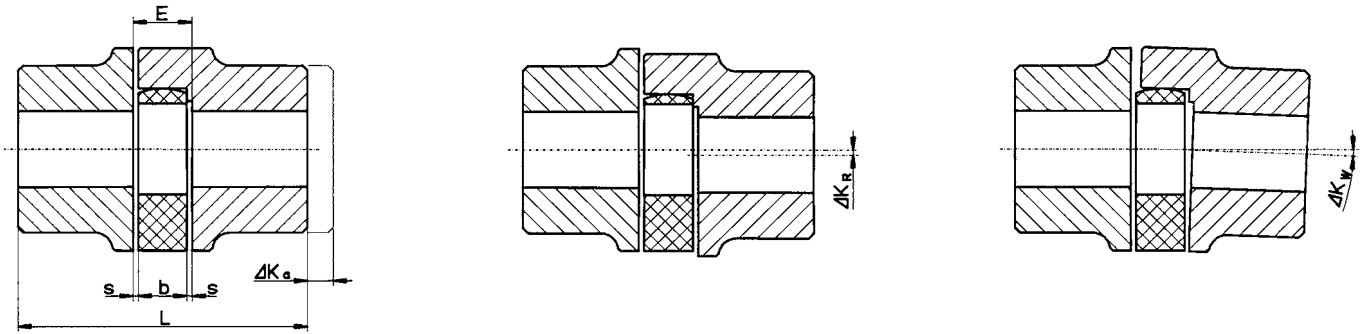

Spidex® Type	Abmessungen [mm] Dimensions [mm]				Axialversatz Axial displace	Radialversatz Radial displace ΔKr [mm]				Winkelversatz Angular displace ΔKw [°]			
	L	E	b	s	ΔKa [mm]	Drehzahl Rotation n[1/min]				Drehzahl Rotation n[1/min]			
						750	1000	1500	3000	750	1000	1500	3000
A14	35	13	10	1.5	1.0	0.22	0.20	0.16	0.11	1.3	1.3	1.2	1.1
A15	28	8	6	1	1.0	0.22	0.20	0.16	0.11	1.3	1.3	1.2	1.1
A19	66	16	12	2.0	1.2	0.27	0.24	0.20	0.13	1.3	1.3	1.2	1.1
A24	78	18	14	2.0	1.4	0.30	0.27	0.22	0.15	1.1	1.0	0.9	0.8
A28	90	20	15	2.5	1.5	0.34	0.30	0.25	0.17	1.1	1.0	0.9	0.8
A38	114	24	18	3.0	1.8	0.38	0.35	0.28	0.19	1.1	1.1	1.0	0.8
A42	126	26	20	3.0	2.0	0.43	0.38	0.32	0.21	1.1	1.1	1.0	0.8
A48	140	28	21	3.5	2.1	0.50	0.44	0.36	0.25	1.2	1.2	1.1	0.9
A55	160	30	22	4.0	2.2	0.54	0.46	0.38	0.26	1.2	1.2	1.1	1.0
A65	185	35	26	4.5	2.6	0.56	0.50	0.42	0.28	1.2	1.2	1.2	1.0
A75	210	40	30	5.0	3.0	0.65	0.58	0.48	0.32	1.3	1.2	1.2	1.0
A90	245	45	34	5.5	3.4	0.68	0.60	0.50	0.34	1.3	1.3	1.2	1.1
A100	270	50	38	6.0	3.8	0.71	0.64	0.52	0.36	1.3	1.3	1.2	1.1
A110	295	55	42	6.5	4.2	0.75	0.67	0.55	0.38	1.3	1.3	1.3	1.1
A125	340	60	46	7.0	4.6	0.80	0.70	0.60	-	1.3	1.3	1.3	-

- 1) Das Längenmaß L vergrößert sich um die angegebenen ΔKa-Werte.
- 2) Die aufgeführten Verlagerungswerte sind allgemeine Richtwerte.
- 3) Bei gleichzeitigem Winkel- und Radialversatz können die angegebenen Werte nur anteilmäßig ausgenutzt werden.
- 4) Die Tabellenwerte sind gültig für eine Betriebstemperatur T = +30°C. Bei einer Temperaturerhöhung müssen die max. zulässigen Radial- und Winkelverlagerungswerte mit dem Temperaturfaktor St multipliziert werden.

- 1) The dimension L extends acc. to the mentioned ΔKa-values.
- 2) The above mentioned displacement values are general guidelines.
- 3) In case of angular and radial displacements at the same time you can use the values only proportionally.
- 4) The values are valid for an operating temperature of T = +30°C. If the temperature increases, you have to multiply the permissible radial and angular displacement values with the temperature factor St.

Temperatur Temperature	-25 < +30 °C	+30 < +40 °C	+40 < +60 °C	+60 < +80 °C
Faktor Safety	1.0	0.8	0.7	0.6

Sorgfältiges Ausrichten der Wellen erhöht die Lebensdauer der Kupplung
Achtung: Montageanleitung beachten

Careful alignment will extend the coupling life
Caution: Notify the assembly instruction

Kegelige Bohrungen Taper bores

Code	Konus 1:8 Taper 1:8			
	ø d	b	t2	l
...N/1	9.75	2.4	10.7	17
...N/1c	11.6	3	12.9	16.5
...N/1e	13	2.4	13.8	21
...N/1d	14	3	15.5	17.5
...N/1b	14.3	3.2	15.7	19.5
...N/2	17.2	3.2	18.3	24
...N/2a	17.2	4	18.9	24
...N/3	22	4	23.4	28
...N/4	25.46	4.78	27.8	36
...N/4b	25.46	5	28.2	36
...N/4a	27	4.78	28.8	32.5
...N/4g	28.45	6	29.3	38.5
...N/5	33.17	6.38	35.4	44
...N/5a	33.17	7	35.4	44
...N/6	43.05	7.95	46.5	51
...N/6a	41.15	8	44.2	42.5

Code	Konus 1:5 Taper 1:5			
	ø d	b	t2	l
A10	9.85	2	10.9	11.5
B17	16.85	3	18.9	18.5
C20	19.85	4	22.0	21.5
Cs22	21.95	3	23.8	21.5
D25	24.85	5	27.9	26.5
E30	29.85	6	32.5	31.5
F35	34.85	6	37.5	36.5
G40	39.85	6	45.5	41.5

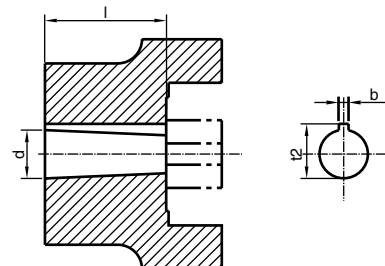

Basisprogramm Zollbohrungen *Standard inch bores*

Typ Type	Nabe Hub	Material Material																														
			V	TA	DNC	S	E	ES	ED	DNH	Ad	AS	A	G	F	B	Bs	H	Hs	Sb	Sd	Js	K	M	C	N	L	KS	NM	D	P	W
A19	A	Al	x	x	x				x	x	x	x	x																			
A19/24	B												x																			
A19	A	GG	x	x				x	x	x			x																			
A19/24	B												x	x																		
A24	A	Al		x	x	x	x	x	x	x	x	x	x	x																		
A24/32	B														x	x																
A24	A	GG		x		x		x	x	x	x	x	x	x																		
A24/32	B															x																
A28	A	Al		x				x		x			x	x	x																	
A28/38	B																															
A28	A	GG								x			x	x	x																	
A28/38	B																															
A38	A	Al								x	x		x	x	x																	
A38/45	B																															
A38	A	GG											x	x																		
A38/45	B																															
A42	A	GG											x	x																		
A42/55	B																															
A48	A	GG											x	x																		
A48/60	B																															

Typ Type	Nabe Hub	Material Material																														
			G	F	K	M	C	N	L	NM	DS	D	P	W	WN	WA	WK															
A55	A	GG	x	x	x	x	x	x	x	x																						
A55/70	B																															
A65	A	GG			x	x	x	x	x																							
A65/75	B																															
A75	A	GG			x		x																									
A75/90	B																															
A90	A	GG																														

Abmessungen Zollbohrungen *Dimensions inch bores*

Code Code	ø d [mm]	Nut Keyway b [mm]	t2 [mm]	Code Code	ø d [mm]	Nut Keyway b [mm]	t2 [mm]	Code Code	ø d [mm]	Nut Keyway b [mm]	t2 [mm]
V	11.11 H7	3.18	12.34	G	22.22	4.75	24.7	C	38.07	9.55	43
TA	12.7	3.17	14.3	F	22.22	6.35	25.2	N	41.29	9.55	46.1
DNC	13.45 H7	3.17	14.9	B	25.37	4.78	27.8	L	44.45	11.11	49.5
S	15.87	3.97	17.9	Ba	25.38 H7	6.35	27.6	NM	47.625	12.73	53.4
E	15.87	3.17	17.5	H	25.4	4.78	27.8	DS	50.77	12.73	56.4
ES	15.88	4	17.7	Sb	28.6	6.35	32.1	D	50.8	12.73	55.1
ED	15.89	4.75	18.3	Sd	28.58	7.93	32.1	P	53.95	12.73	59.6
DNH	17.485 H7	4.75	19.6	Js	31.75	6.35	34.62	W	60.37	15.87	68.8
Ad	19.02	3.17	20.7	K	31.75 K7	7.93	35.5	WN	73.025	19.05	83
AS	19.02	4.78	21.3	KS	31.75	7.93	36.6	WA	85.78	22.22	97.3
A	19.05	4.78	21.3	M	34.94	7.93	39	WK	92.08	22.22	103.3

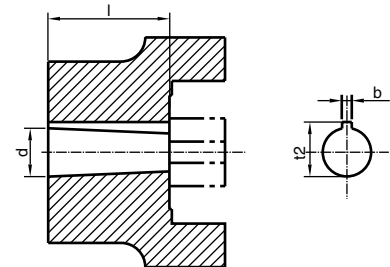

Verzahnungsvarianten *Available splines*

Profil DIN 5480 Spline DIN 5480	Profil DIN 5482 Spline DIN 5482	Profil SAE SplineSAE
N 20 x 1.25 x 14 x 9 G	A 17 x 14	16/32 x 9 J 498 B
N 25 x 1.25 x 18 x 9 G	A 28 x 25	16/32 x 10 J 498 B
N 30 x 2 x 14 x 9 G	A 30 x 27	16/32 x 11 J 498 B
N 35 x 2 x 16 x 9 G	A 35 x 31	16/32 x 13 J 498 B
N 40 x 2 x 18 x 9 G	A 40 x 36	16/32 x 15 J 498 B
N 45 x 2 x 21 x 9 G	A 45 x 41	16/32 x 21 J 498 B
N 50 x 2 x 24 x 9 G	A 48 x 44	16/32 x 23 J 498 B
N 55 x 2 x 24 x 9 G	A 50 x 45	16/32 x 27 J 498 B
N 60 x 2 x 28 x 9 G	A 58 x 53	12/24 x 14 J 498 B
N 70 x 3 x 22 x 9 G	A 70 x 64	12/24 x 17 J 498 B
N 80 x 3 x 25 x 9 G		8/16 x 13 J 498 B
N 90 x 3 x 28 x 9 G		3/4 x 6 J 498 B

Kupplungs-naben mit Verzahnung sind vorzugsweise als Klemmnabe einzusetzen! Erhältlich jedoch auch ohne Klemmung mit Feststellschraube.

Coupling-hubs with spline are recommended as clamping-hub! Available also with set screw.