

Einfüll- und BelüftungsfILTER *Filler and Breather filter*

Typ *Type* EB80-10

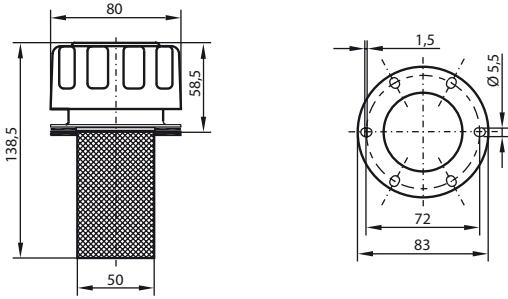

6 Langlöcher für selbstschneidende Gewindeschrauben M5 x 12 mm, für Lochkreis Ø 70,5 - 73,5 mm.

6 slots for selftapping screws M5 x 12 mm, for pitch circle diameter Ø 70.5 - 73.5 mm.

Typ *Type* EB50-10

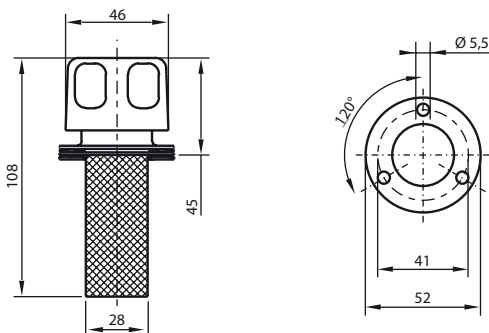

3 Löcher für selbstschneidende Gewindeschrauben B 4,8 x 13 mm.

3 holes for selftapping screws B 4.8 x 13 mm.

Typ *Type* E35 ES

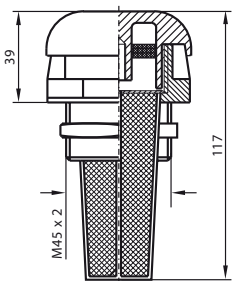

Ölstandsanzeiger *Oil level gauges*

SF1 – SF3

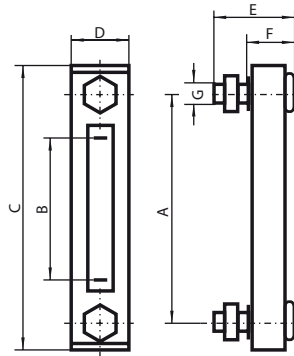

Ölschaugläser *Oil level windows*

KL13, KL33, A18

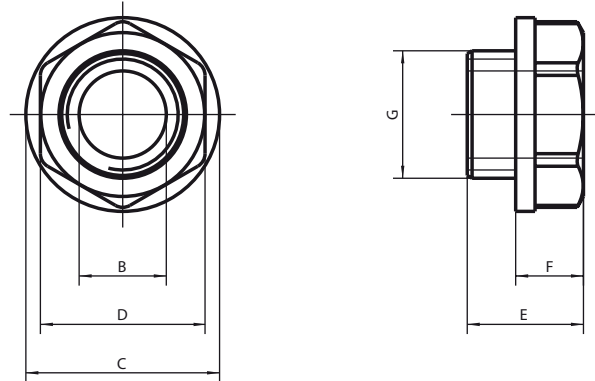

Typ <i>Type</i>	Abmessungen [mm] <i>Dimensions [mm]</i>						
	A	B	C	D	E	F	G
SF1 / SF1 Th	76	32	108	34	45	28	M12
SF2 / SF2 Th	127	76	159	34	45	28	M12
SF3 / SF3 Th	254	203	286	34	45	28	M12
KL13	–	ø 9	ø 20	SW17	16	7	G¼"
A18*	–	ø 18	ø 35	SW32	18.5	8.5	G¾"
KL33	–	ø 23	ø 42	SW34	24	11	G1"

*A18 mit Mutter *A18 with nut

Typ <i>Type</i>	Ausschnitt Behälterdeckel <i>Recess tank lid</i>	Ausführung <i>Material</i>	Maschenweite <i>Mesh aperture</i>
E35 ES	ø 46 mm	Kunststoff <i>Plastic</i>	45 Micron
EB50-10	ø 29 mm	Metall <i>Metal</i>	10 Micron
EB80-10	ø 51 mm	Metall <i>Metal</i>	10 Micron