

## Dämpfungsschienen *Damping rods*



- Für Elektromotoren Bauform IM B35 und Fußflansche nach VDMA 24 561
- Ausgelegt für die Gewichtsbelastung bei horizontalem Einbau
- Schallreduzierend und schwingungsdämpfend
- Mineralölbeständigkeit durch NBR-Gummimischung

- For electric motors with frame size IM B35 and footbrackets acc. VDMA 24 561
- Dimensioned for loads in case of horizontal mounting
- Noise absorbing and vibration damping
- Resistance against mineral-oil because of NBR-rubber

**Typenbezeichnung**  
Model type

**P T F S D L 660**

Dämpfungsschienen-Typ Type of damping rod	
Elektromotoren Electric motors	MDL
Fußflansche schwer Footbrackets heavy duty	PTFSDL
Fußflansche leicht Footbrackets light	PTFLDL

Nenngröße  
(siehe Tabelle unten)  
Size of rod  
(see table below)

**Abmessungen**  
Dimensions

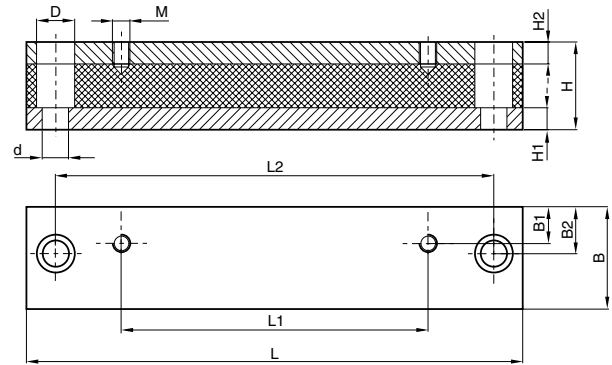

**Dämpfungsschienen**  
Damping rods

Dämpfungsschienen Type of damping rod	Für Typ For type	L	L1	L2	H	H1	H2	B	B1	B2	d	D	M
<b>Für Elektromotoren For electric motors</b>													
MDL71	71	196	90	156	40	8	12	50	21	25	14	20	M6
MDL80	80	196	100	156	40	8	12	50	22	25	14	20	M8
MDL90S	90S	196	100	156	40	8	12	50	22	25	14	20	M8
MDL90L	90L	240	125	205	40	8	12	50	24	25	14	20	M8
MDL100L	100L	240	140	205	40	8	12	50	24	25	14	20	M10
MDL112M	112M	240	140	205	40	8	12	50	20	25	14	20	M10
MDL132S	132S	285	140	245	45	8	12	50	20	25	14	20	M10
MDL132M	132M	285	178	245	45	8	12	50	20	25	14	20	M10
MDL160M	160M	340	210	300	60	15	15	70	28	35	18	26	M12
MDL160L	160L	416	254	370	60	15	15	70	28	35	18	26	M12
MDL180M	180M	416	241	370	60	15	15	70	35	35	18	26	M12
MDL180L	180L	446	279	400	60	15	15	70	35	35	18	26	M12
MDL200L	200L	496	305	430	60	15	15	70	35	35	22	32	M16
MDL225S	225S	496	286	430	60	15	15	70	35	35	22	32	M16
MDL225M	225M	496	311	445	60	15	15	70	35	35	22	32	M16
MDL250M	250M	496	349	445	60	15	15	100	50	50	25	40	M20
MDL280S	280S	580	368	530	60	15	15	100	50	50	25	40	M20
MDL280M	280M	580	419	530	60	15	15	100	50	50	25	40	M20
MDL315S	315S	660	406	610	70	15	15	150	60	75	25	40	M24
MDL315M	315M	660	457	610	70	15	15	150	60	75	25	40	M24
MDL315L	315L	720	508	670	70	15	15	150	60	75	25	40	M24
MDL355L	355L	960	630	860	80	20	20	130	70	65	25	40	M24
MDL355S	355S	960	500	860	80	20	20	130	70	65	25	40	M24
<b>Für Fußflansche For footbrackets</b>													
PTFSDL250	PTFS 250	290	185	260	40	8	12	50	20	25	14	20	M12
PTFSDL300	PTFS 300	350	225	300	40	8	12	50	20	25	14	20	M12
PTFSDL350	PTFS 350	375	265	340	60	8	12	70	30	35	18	26	M16
PTFSDL400	PTFS 400	420	300	385	60	15	15	70	30	35	18	26	M16
PTFSDL450	PTFS 450	455	335	420	60	15	15	70	30	35	18	26	M16
PTFSDL550	PTFS 550	535	415	500	60	15	15	70	30	35	18	26	M16
PTFSDL660	PTFS 660	660	495	610	60	15	15	70	30	35	22	32	M20
PTFLDL160	PTFL 160	176	50	130	40	8	12	50	10	25	14	20	M8
PTFLDL200	PTFL 200	176	60	130	40	8	12	50	15	25	14	20	M10
PTFLDL250	PTFL 250	230	60	140	40	8	12	50	15	25	14	20	M12
PTFLDL300	PTFL 300	270	80	170	40	8	12	50	15	25	14	20	M12

Sonderausführungen auf Anfrage Special versions on request